



# LOWE & FLETCHER

LOCKING SYSTEMS FOR INDUSTRY

**The Easy-Fit Document Lock has been designed to be fitted to most doors or drawers as a convenient security measure.**

The kit is supplied with the following items:

1x Front Plate Assembly

1x Side Plate

1x Set of 2 Keys

2x 3M VHB® Adhesive Pads

2x 3M VHB® Degreasing Alcohol Wipes

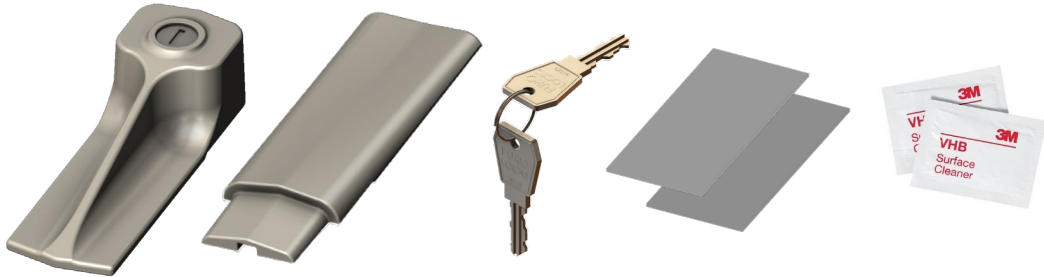

### Before you start the installation!

Plan out thoroughly where the lock is to be positioned on the drawer or door. Take into account that the Adhesive Pads should mate to smooth, flat surfaces free from badges, vents or ribs, as these may prevent the Adhesive Pads adhering. You may need to trim the Adhesive Pads to the correct size for your application. It is important that you DO NOT YET peel off the protective layers from the Adhesive Pads.

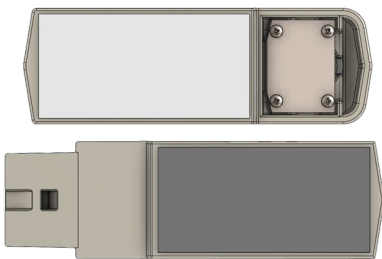

- Using one alcohol wipe, clean both flat mounting surfaces
- Peel one side of each adhesive pad and mount them centrally onto the mounting faces of both the Front Plate Assembly and Side Plate

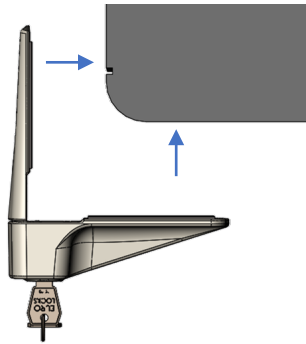

- Using the second alcohol wipe, clean the surfaces of the enclosure where the lock is to be fitted
- Slide both the Front Plate Assembly and the Side Plate together until they 'click' into place
- Remove the protective layer of the Adhesive Pad on the Side Plate only and push the whole assembly firmly into its intended position

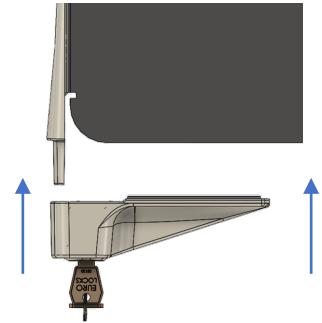

- Unlock the Front Plate Assembly and remove it from the Side Plate
- Remove the protective layer of Adhesive Pad on the Front Plate
- Slide the Front Plate Assembly onto the Side Plate and push the Front Plate Assembly firmly into position